



# CEN TEK

## INDUSTRIES



**MARINE SOLUTIONS**



Centek Marine builds the best exhaust components and systems for the best boats in the world. Whether propulsion engines or gen-sets, ski boats to mega yachts and all in between, we can design and build it for you.

[centekmarine.com](http://centekmarine.com)



Delta-T Systems is the world leader in marine engine room ventilation, with systems on board more than 19,000 vessels around the world.

[deltatsystems.com](http://deltatsystems.com)

# TABLE OF CONTENTS

---

|           |  |       |
|-----------|--|-------|
| <b>4</b>  | Centek Marine Propulsion Wet Exhaust Solutions         | ..... |
| <b>6</b>  | Centek Marine Generator Wet Exhaust Solutions          | ..... |
| <b>8</b>  | Centek Marine Generator Exhaust Filtration Solutions   | ..... |
| <b>10</b> | Centek Marine Systems Modular Dry Exhaust Solutions    | ..... |
| <b>12</b> | Centek Marine Filament Wound Tubing Solutions          | ..... |
| <b>14</b> | Centek Product Categories                              | ..... |
| <b>16</b> | Delta-T Systems Engine Room Ventilation Solutions      | ..... |
| <b>18</b> | Delta-T Systems Airflow Solutions                      | ..... |
| <b>20</b> | Delta-T Systems Moisture Eliminator Solutions          | ..... |
| <b>22</b> | Delta-T Systems Fire Damper Solutions                  | ..... |
| <b>24</b> | Delta-T Systems Marine Off-Load Release Hook Solutions | ..... |
| <b>26</b> | Delta-T Systems Head Vent Solutions                    | ..... |
| <b>28</b> | Delta-T Systems Product Categories                     | ..... |



# OPTIMAL SOUND ATTENUATION, PURPOSEFULLY DESIGNED, FULLY ENGINEERED EXHAUST SOLUTIONS

Let Centek Marine design the perfect exhaust system to meet your specific needs. Design it, engineer it, build it, test it, ship it – that is what we do at Centek Marine.

- ✓ **Materials** – Highest quality, heat resistant, flame retardant, self-extinguishing resin. We don't settle for anything less, and neither should you. Centek's fiberglass is the only serious choice.
- ✓ **Engineering** – Experts in our craft. Professional Engineering Company offering CAD & 3D modeling, ISO 9001:2015 certification and Lloyd's Registered approval.
- ✓ **Customization** – A Centek specialty. We can design to meet your engine specs, available space, and sound attenuation goals. We make it easy.
- ✓ **Recognized industry leader** – 60-year history, Centek Marine invented wet exhaust for the boating world. Obsessed with innovation.
- ✓ **Full systems** – From the turbo flange to the thru hull and all in between, Centek Marine can design and provide exactly what you need and back it up with the best warranty in the business.

## How it works.

[centekmarine.com/solutions/propulsion-wet-exhaust](http://centekmarine.com/solutions/propulsion-wet-exhaust)

Centek Marine engineers design exhaust systems based on variables such as engine location in relation to the water line, engine specs, and sound attenuation goals. For engines located below the water line, a lift muffler configuration is used while above the water line installations call for an in-line style as seen in the diagram below. While there are thousands of standard mufflers available, custom engineered solutions are always an option. And don't forget items such as tubing, check valves, surge chambers, wye fittings, thru hull fittings and anything else you need. Centek Marine is a one stop shop. Below is a general configuration and how it works:

- 1 Cooling water mixes with exhaust gas** – reduces exhaust temperatures. Mixing tanks, risers, spray rings – let Centek Marine design and provide it.
- 2 Muffler** – engineered to attenuate the sound produced by the engine. Takes the cooling water mixed with the exhaust gas and effectively baffles the noise while balancing backpressure allowances specified by the engine manufacturer.

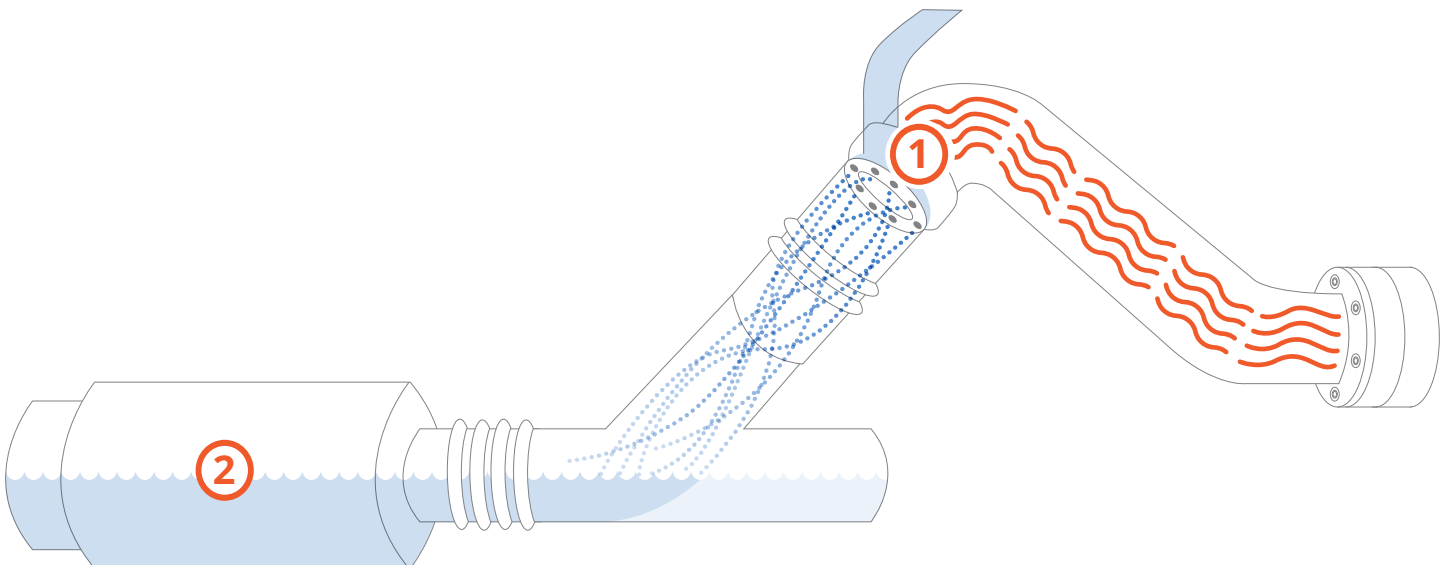





## PEACE AND QUIET ... EVEN WITH THE GENERATOR RUNNING.

Centek Marine can make your gen-set quieter and even get rid of the annoying splash and gurgle so you can enjoy your time on the water....and so can your neighbors.

- ✓ **Materials** – Highest quality, heat resistant, flame retardant, self-extinguishing resin. We don't settle for anything less, and neither should you. Centek fiberglass is the only serious choice.
- ✓ **Engineering** – Experts in our craft. Professional Engineering Company offering CAD & 3D modeling, ISO 9001:2015 certification and Lloyd's Registered approval.
- ✓ **Recognized industry leader** – 60-year history, Centek Marine invented wet exhaust for the boating world. We know generators through and through and have seen it all.
- ✓ **Customization** – A Centek specialty. We can design to meet your generator specs, available space, and sound attenuation goals. You have options.

## How it works.

[centekmarine.com/solutions/generator-wet-exhaust](http://centekmarine.com/solutions/generator-wet-exhaust)

Centek Marine engineers design generator exhaust systems based on variables such as engine location in relation to water line, generator specs, desired discharge location, and sound attenuation goals. We make the process easy.

- 1 Lift muffler** – Exhaust gas and cooling water enter the lift muffler from the generator and is lifted above the waterline for either discharge overboard or to an optional Gen-Sep.
- 2 Gen-Sep** – Separates exhaust gas from cooling water. Gas is vented to atmosphere and cooling water discharged below waterline. Gets rid of the annoying splash and gurgle.
- 3 Combo-Sep** – For at or above the waterline installations. Combines lift muffler and gen-sep into one space saving unit. Available in vertical or horizontal configuration.

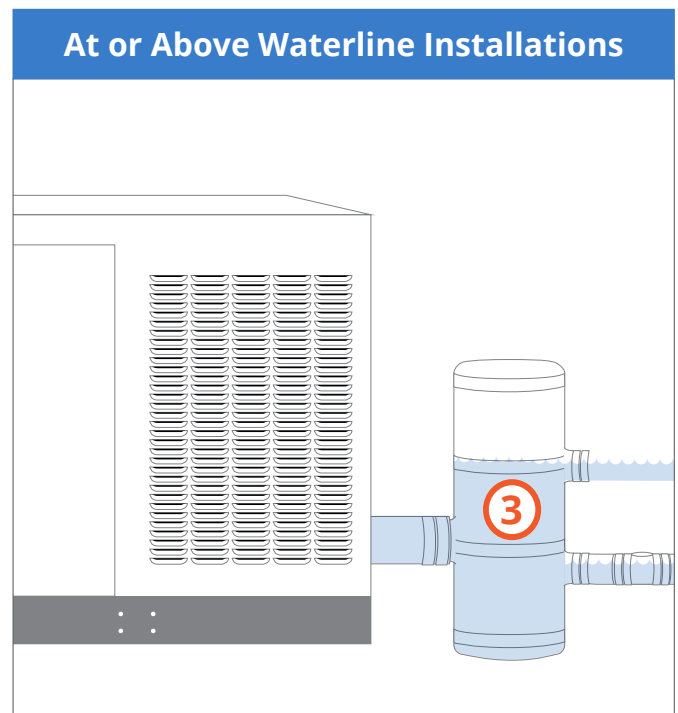
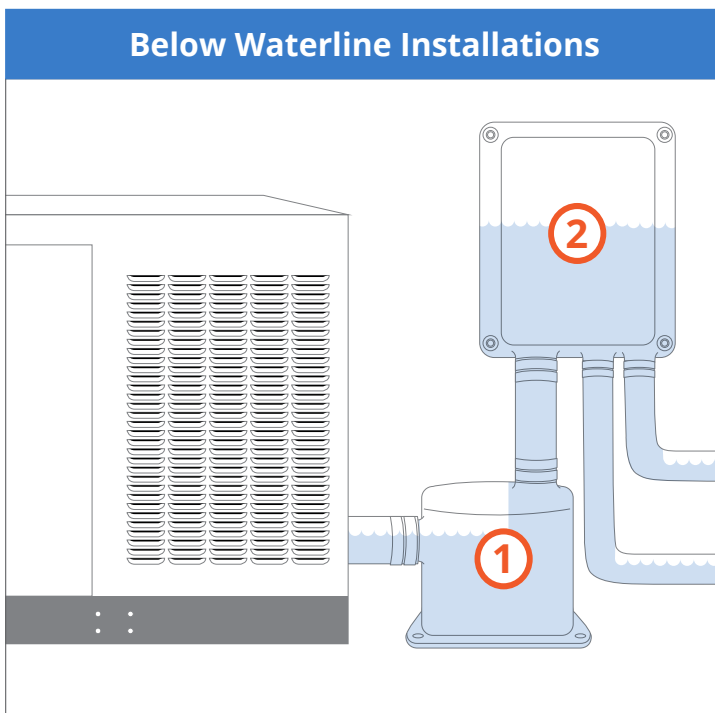



# ENJOY YOUR TIME ON THE WATER – SHEEN FREE.

With Centek Marine's family of **Gen-Kleen** filtration systems, you don't have to swim in the oily sheen that forms around your boat when the generator is running. Filter the hydrocarbon pollution from the generator's cooling water before it is discharged overboard into the environment.

- ✓ Systems available for ALL generators from 5kW and above
- ✓ Centek engineers will size a system based on your generator specs and available space
- ✓ Excellent filter life – 250+ hours depending on your generator and operating loads
- ✓ Easy to change filter cartridges
- ✓ Creates no additional backpressure to gen-set or heat to the engine room
- ✓ Time tested, proven technology



## How it works.

[centekmarine.com/solutions/generator-exhaust-filtration](http://centekmarine.com/solutions/generator-exhaust-filtration)

A Gen-Kleen Filtration System keeps the sheen off the water by separating the generator's cooling water from exhaust gas and then filtering the hydrocarbon pollution before it is discharged overboard. Centek engineers can tailor your system by organizing and combining the various components. Below is a general visualization of how Gen-Kleen works.\*

- 1 Lift muffler** – Exhaust gas and cooling water enter the lift muffler from the generator and are lifted above the waterline to the Smart-Sep™.
- 2 Smart-Sep™** – Install above lift muffler and above water line. Separates the cooling water from the exhaust gas. Exhaust gas is vented to atmosphere and cooling water is stored in the internal reservoir.
- 3 Control Panel** – Operates the system by controlling pump which transfers polluted cooling water to the filter canister. Bypass feature allows operator to choose when filtering takes place.
- 4 Pump** – Transfers polluted water from reservoir to filter canister then pumps clean water overboard.
- 5 Filter Housing** – Contains patented filter that binds to hydrocarbon pollution and allows clean water to pass through freely.

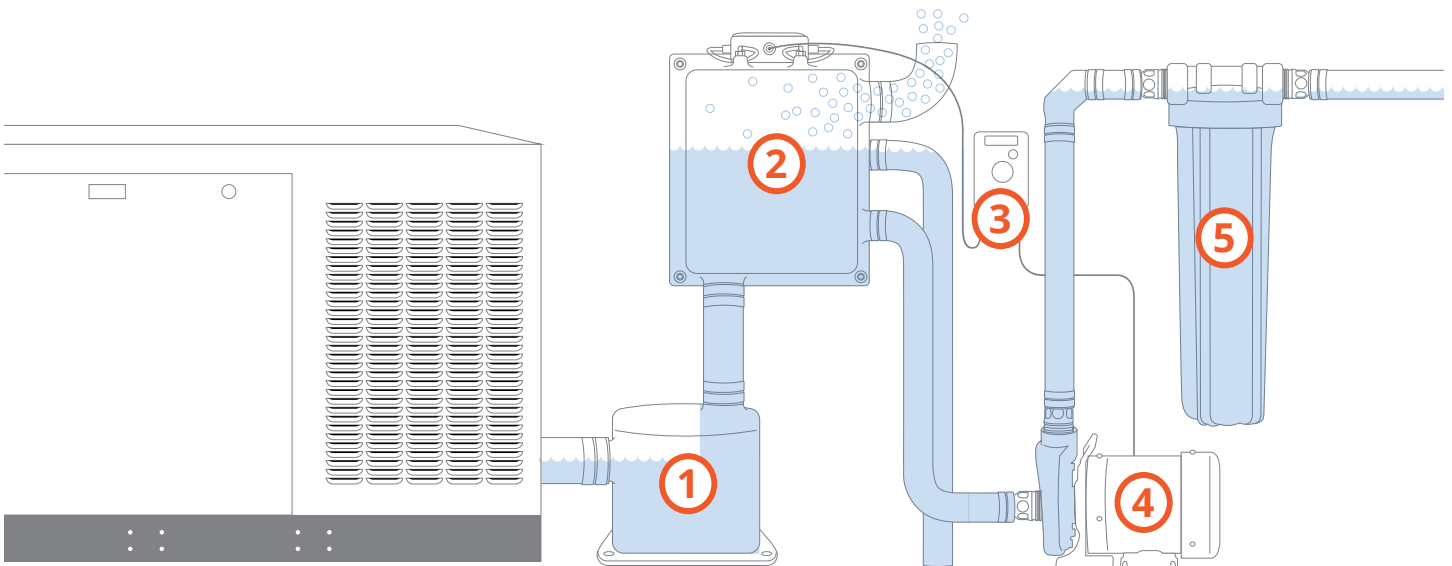

\* Gen-Kleen SL configuration shown



## LIGHT WEIGHT, SIMPLE TO INSTALL, REPLACEABLE MODULAR COMPONENTS, OPTIMAL PERFORMANCE

Gone are the days of heavy, difficult to install and maintain welded dry exhaust systems. Dinak Modular Dry Exhaust solutions are the future of dry exhaust stacks – available now thru Centek Marine.

- ✓ **Light weight components** – a fraction of the weight of welded, stainless steel exhaust pipes
- ✓ **Interior insulation** - no bulky, expensive, hard to maintain insulation blankets required
- ✓ **Cost savings** – reduced installation time, no welding or pipe fitting required, light weight reduces fuel burn, modular components mean simple maintenance
- ✓ **Engineering** – Let Centek Engineering design the system for you. CAD and 3D models standard. Professional installation teams available.
- ✓ **Approvals** – Lloyds and ABS Type Approved. Welded pipe? Class approval on case -by – case basis only.

## Why it works.

[centekmarine.com/solutions/dry-exhaust](http://centekmarine.com/solutions/dry-exhaust)

Centek Engineers will design a system to your exact specifications. Everything you need for assembly is included. Save time and money with the easy installation – no need for welders on site. Dinak Dry Exhaust is simply the best solution.

- 1 Flanged connection** - traditional flanged connections to manifold, optional muffler, and expansion joints.
- 2 Modular components** – designed for your application with all necessary parts.
- 3 Easy to assemble** – no welding necessary, components fit easily together and seal with silicon strap and v-band style clamp. All items necessary to assemble system are included.
- 4 Muffler** – optional muffler available depending on your sound attenuation goals.
- 5 Construction** – 304 and 316 stainless steel, double walled with interior insulation – no need for bulky, expensive insulation blankets.

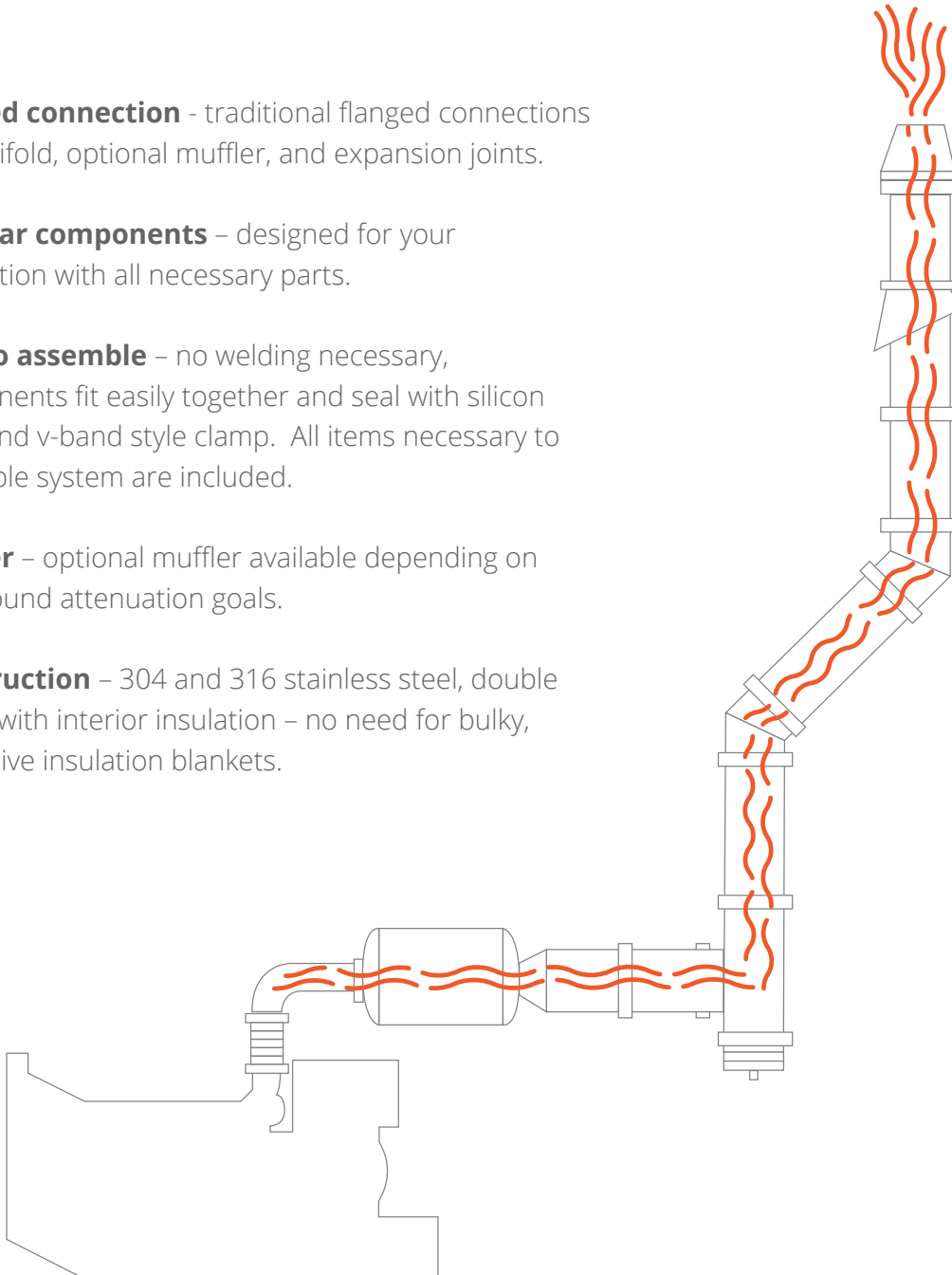

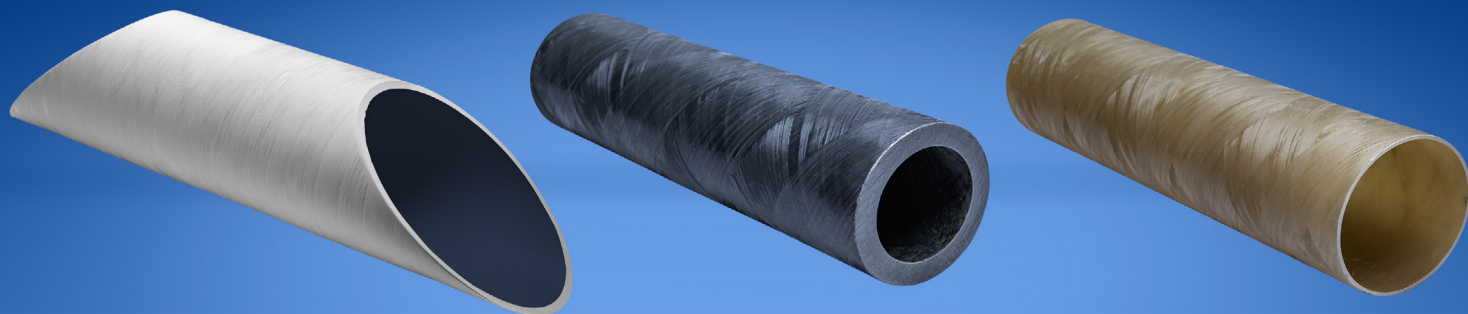

## FIBERGLASS TUBING – SEEMS SIMPLE, UNTIL YOU TAKE A CLOSER LOOK.

From standard dimensions and lengths to custom geometries for very specific uses, Centek Marine has the solution. Not all fiberglass tubing is created equal. Centek is your best choice, period.

- ✓ **Materials** – continuous strand E glass and high temperature, self-extinguishing resin makes the perfect combination for marine tubing.
- ✓ **Filament winding** – cnc winders lay the continuous strand glass on the mandrel at precise angles for an unrivaled strength to weight ratio.
- ✓ **Smooth ID** – perfect for un-restricted flow of exhaust gas/cooling water mixture or whatever else is running through.
- ✓ **Customization** – a Centek specialty! Vary the wall thickness, the length, the angle cuts, whatever you need. Engineers are ready to draw it for your approval.

## Where it works.

[centekmarine.com/solutions/tubing-solutions](http://centekmarine.com/solutions/tubing-solutions)

There are literally hundreds of uses – the only limitation is imagination. From straight runs to intricately cut, custom designs, Centek Marine has the solution. Consider just a few of the more popular uses:



**Exhaust Tubing** – the original use. Smooth ID facilitates un-restricted flow, flame retardant/heat resistant resin, OD sized for common hose dimensions.

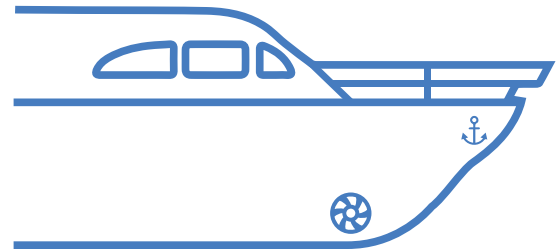

**Thruster Tunnels** – tons of options available from raw tubes to gel-coated IDs to match hull colors. Let Centek cut it to your exact requirements and save you time and money on the line.

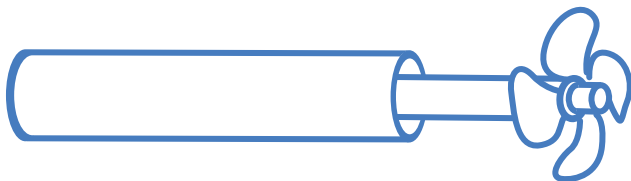

**Shaft Log/Rudder Post Housing** – Custom dimensions available. Vinyl ester resin used has extremely low water absorption properties.



**Wire Trace** – don't use PVC or conduit from Home Depot in your boat. Seriously! Fiberglass tubing from Centek bonds perfectly and lasts virtually forever. Let us cut and kit up exactly what you need.





### **Propulsion Wet Exhaust**

<https://centekmarine.com/product/category/propulsion-exhaust/>

---



### **Generator Wet Exhaust**

<https://centekmarine.com/product/category/generator-exhaust/>

---



### **Environmental**

<https://centekmarine.com/product/category/environmental/>

---



### **Dry Exhaust**

<https://centekmarine.com/product/category/dry-exhaust/>

---

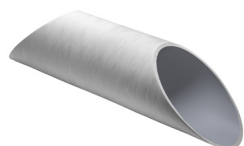

### **Tubing**

<https://centekmarine.com/product/category/tubing/>

---



### **Components**

<https://centekmarine.com/product/category/components/>

# NOTES

---

A series of horizontal dotted lines for writing notes.

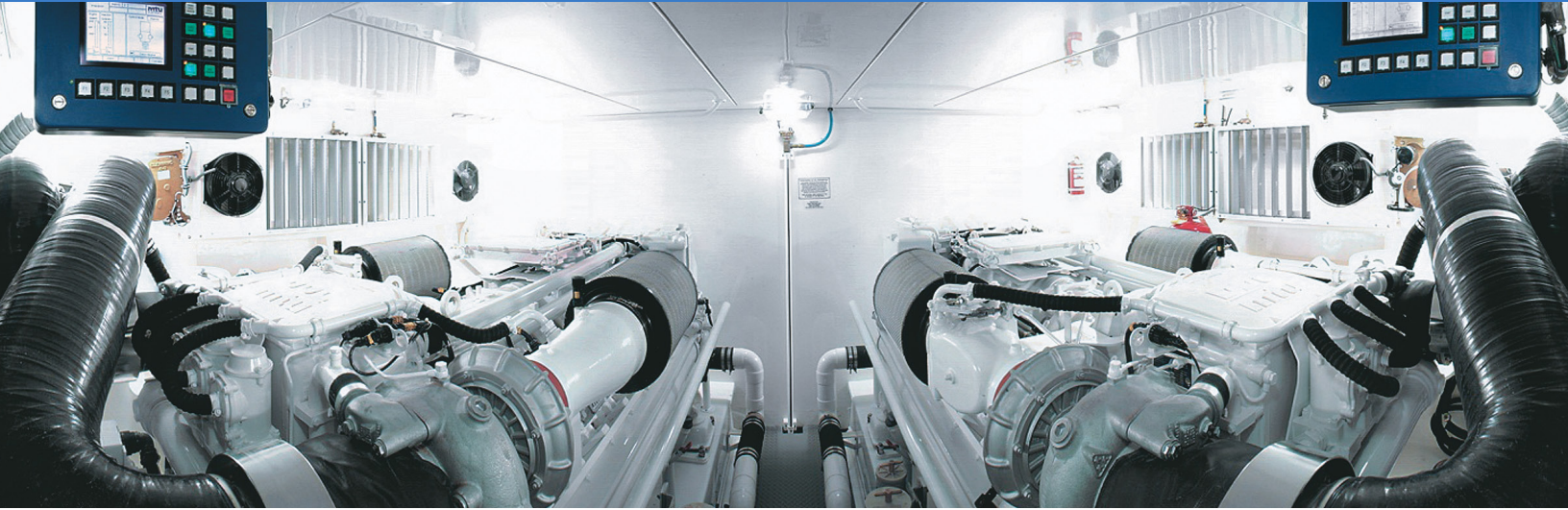

# Optimal Engine Performance, Longevity, and Safety

*Balance proper air flow and temperature, prevent saltwater intrusion, mitigate catastrophic engine room fires all with smart, intuitive controls. That is what we do at Delta-T Systems.*



**Air** – Fresh air in, hot air out. Expertly engineered solutions for optimal engine performance, longevity, and cost savings.

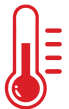

**Temperature** – A balanced ventilation system is critical for keeping engine room temperatures at the perfect level. Protect man and machine with properly engineered solutions.



**Moisture** – Water, especially salt water, has no place in the engine room. Stop it at the source with strategic placement of moisture eliminators in the air intake openings.



**Fire** – Fuel, heat, air – in combination – can spell catastrophic engine room fire. Help prevent it with properly engineered dampers. Coast Guard approved, trusted worldwide.



**SMART Controls** – Fans working in harmony, temperature and air pressure optimized, moisture removed, dampers closed in case of fire. At the touch of a button or automatically.

## How it works.

[deltasystems.com/solutions/engine-room-ventilation](http://deltasystems.com/solutions/engine-room-ventilation)

- ① Moisture Eliminators** – Uniquely designed louvers stop moisture from entering the engine room. Helps prevent corrosion that can destroy engine room equipment.
- ② Dampers** – Remain open during normal operation but close automatically to seal off air in case of a fire event. Critical so that fire suppression systems can do their job.
- ③ Marine Fans** – Engineered to bring the proper amount of fresh air in and exhaust the hot air out. Balances the flow for optimal engine performance and crew safety.
- ④ Control System** – The brains of a properly engineered ventilation solution. Coordinates multiple fans to achieve optimal temperature and pressure in the engine room.

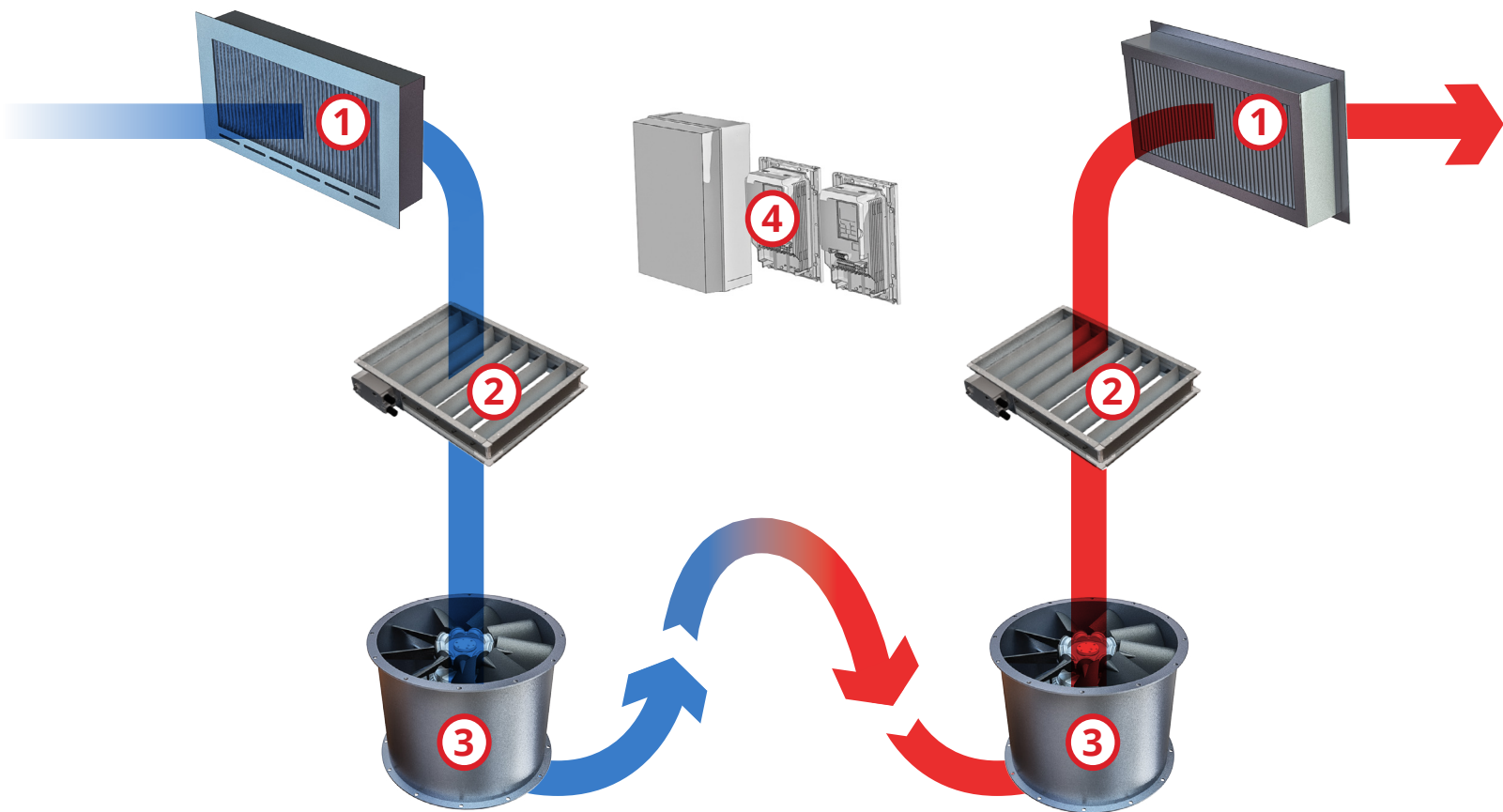



## **PULL THE FRESH, COOL AIR IN. PUSH THE HOT AIR OUT. A PERFECTLY BALANCED APPROACH.**

*Purposefully designed for the harsh, marine environment. Fans, whether large or small, play an integral part in a properly engineered ventilation system.*

- ✓ Robust, highly efficient and rated for continuous use.
- ✓ Extensive line includes AC and DC axial fans and centrifugal blowers.
- ✓ 8" - 36" standard sizes with custom sizes available.
- ✓ Premium three-phase and single-phase motors designed for quietness and worldwide use.



## Why it works.

[deltatsystems.com/solutions/airflow](https://deltatsystems.com/solutions/airflow)

Properly engineered fans, which move the correct amount of air, are a vital part of a balanced ventilation system. Delta-T fans are specifically designed and built to be the best in class.

- ① Exact tolerances and intricate design determine the overall efficiency – Delta-T individually produces each hub/blade assembly for a perfect fit.
- ② Externally mounted junction boxes maximize airflow and simplify wiring connections.
- ③ Hubs are mounted directly to the motor shaft and balanced for safety and reliability.
- ④ Entire fan is made specifically for the marine environment.

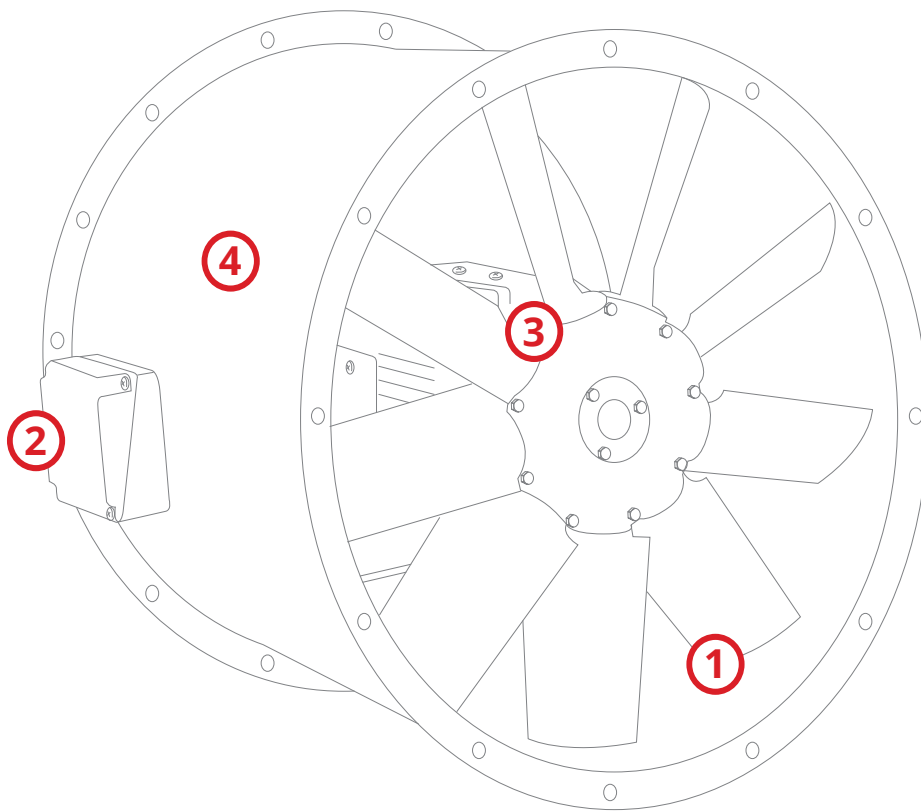



## **STOP THE INTRUSION OF CORROSIVE SALT WATER BEFORE IT GETS TO YOUR ENGINE SPACE.**

*Salt water has no place in the engine room or anywhere else on board. Stop it from entering with a Delta-T Moisture Eliminator. It is too costly not to!*

- ✓ Impingement design separates water droplets as small as 10 microns from the airflow
- ✓ Engineered for vertical or horizontal airflow
- ✓ Profiles available in white or black PVC or Aluminum
- ✓ Customization available to fit unique openings
- ✓ Design and engineering help a phone call away

## How it works.

[deltasystems.com/solutions/moisture-eliminator](http://deltasystems.com/solutions/moisture-eliminator)

- ① An elegant solution to a real problem on any boat. The Moisture Eliminator is specifically engineered to remove the damaging water in a simple yet effective way.
- ② As moist air passes over the profiles, droplets are entrapped to form a film and then collect to form larger droplets.
- ③ Gravity pulls the droplets to the bottom of the eliminator, and they drain overboard.
- ④ Custom configurations available to fit any opening.

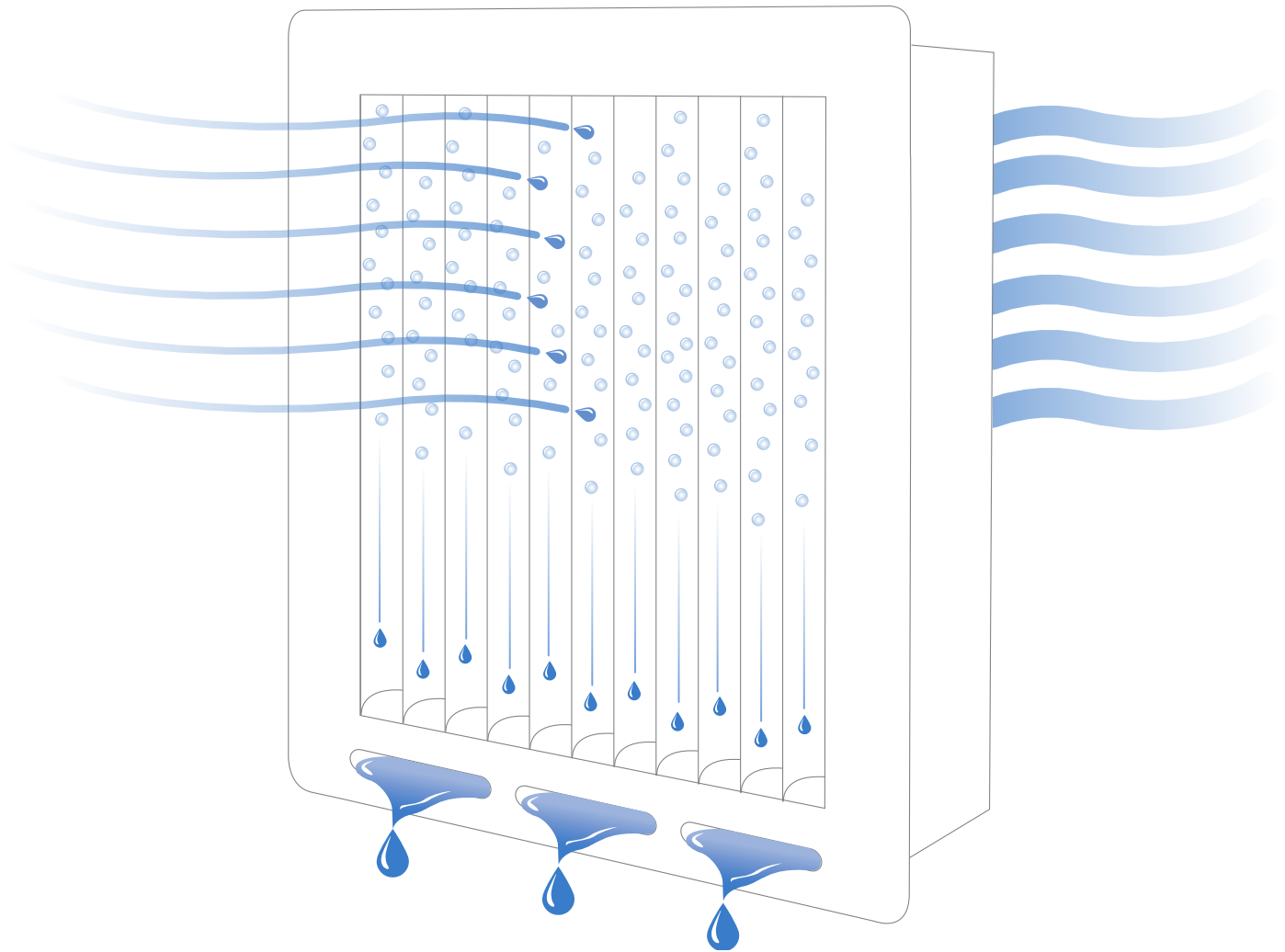



## ROBUST, FAILSAFE FIRE DAMPERS – LEAVE NOTHING TO CHANCE

*When it comes to crew and passenger safety, fire dampers by Delta-T Systems are the only serious choice.*

- ✓ Unique design of closure and actuator assure failsafe operation
- ✓ A-60 rated dampers are USCG approved
- ✓ Suitable for use with a wide range of fire suppression systems
- ✓ Wide range of standard sizes - custom designs available for most any application

## How it works.

[deltatsystems.com/solutions/fire-damper](https://deltatsystems.com/solutions/fire-damper)

Properly designed and engineered fire dampers play a critical role in a safe ventilation system.

- ① When open, allows fans to pull fresh air in and push hot air out
- ② Test switch allows for operational checks and inspections without having to replace the device
- ③ In the event of a fire, the actuator closes the blades so the firefighting equipment can do its job
- ④ Patented, overlapping blades assure secure closure

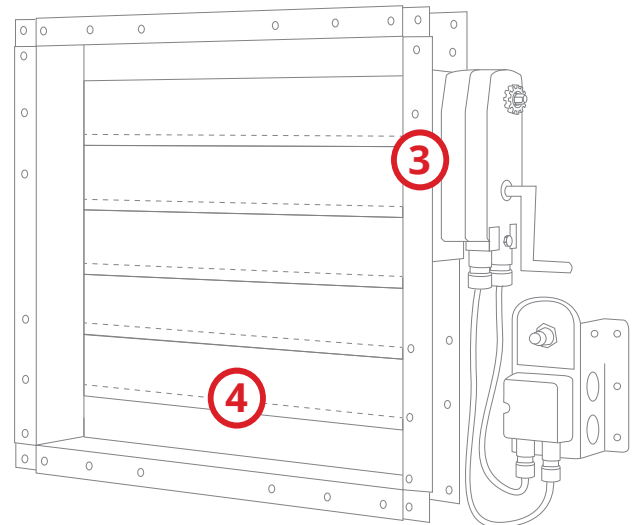
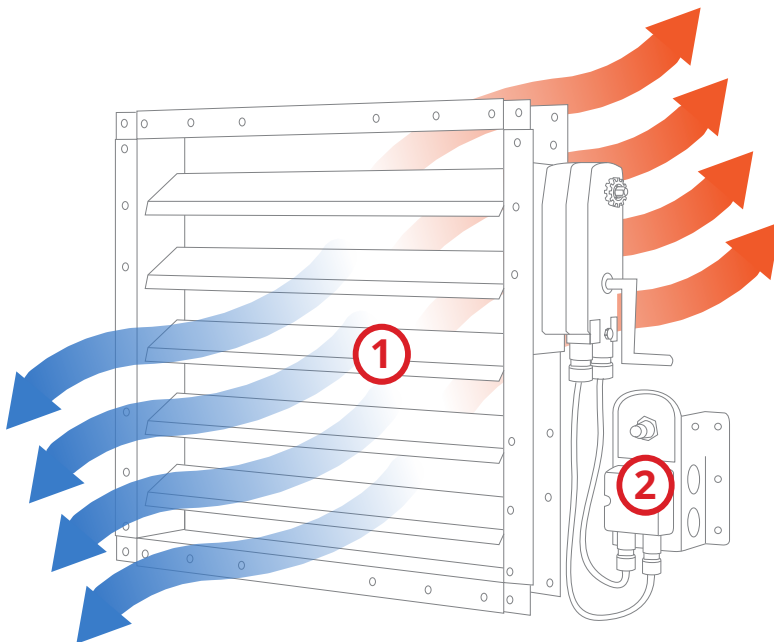



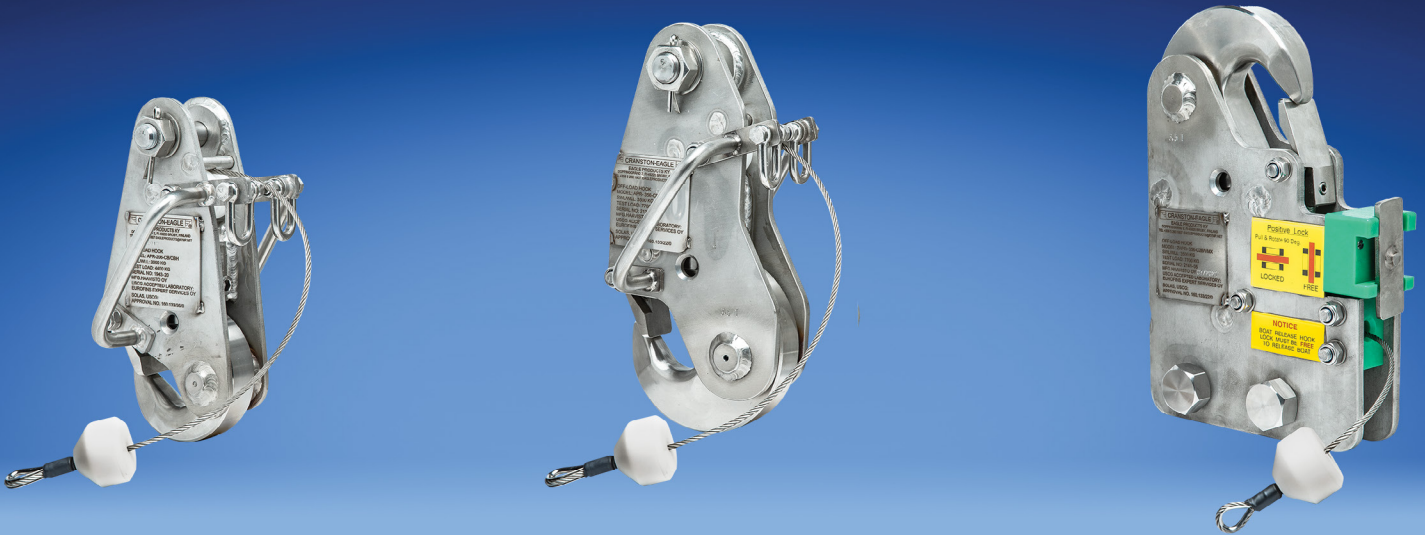

# Never Compromise On Safety.

**Cranston Eagle Hooks** – simply the best boat and fall mounted release hooks available. Exclusively distributed and re-certified through Delta-T Systems.

All stainless-steel construction with models from two to twelve tonnes. Tested to 6 times it's rated safe working load for the maximum in lifting safety and reliability.

**Boat Mounted Hooks** – Open boat and roof mounted hooks for a wide variety of vessel lifting applications.

**Fall Mounted Hooks** – Cable mounted hooks either with or without shackles for use on davit and crane applications.

**Approvals** – US Coast Guard/ SOLAS (Approval Nos. 160.133/22/0, 160.133/35/0, 160.133/65/0, 160.133/77/0).

**Load Testing and Certification Services** – Delta-T offers load testing, rebuilding and recertification services with documentation to help you stay on top of the 5-year SOLAS and IMO requirements.

## How it works.

[deltatsystems.com/solutions/off-load-release-hook](http://deltatsystems.com/solutions/off-load-release-hook)

- ① **Overdesigned Stainless Steel Bodies** – Robust, welded stainless steel bodies and simple mechanical designs make Cranston Eagle hooks reliable and trouble free.
- ② **Negative Angle Lock Pins** – Lock pins mechanically designed to open only when load is completely off the hook. The safest type of marine release hook.
- ③ **Lock Inspection Hole** – Allows quick confirmation that lock pin is fully engaged and the hook is ready for use.
- ④ **Bolt On Peripheral Parts** – All peripheral parts are bolted to the frame. Maintenance and component replacement fast and easy either on the workbench or in the field.

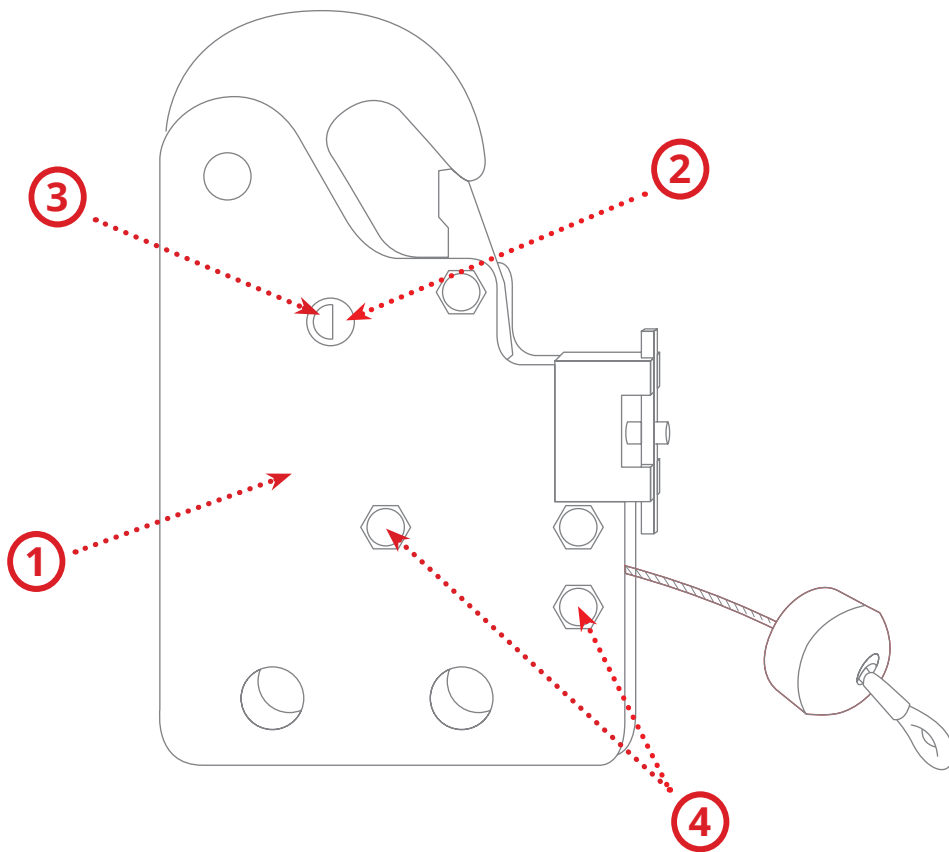



## SOME THINGS ARE JUST TOO CLOSE FOR COMFORT. DELTA-T SYSTEMS HAS THE PERFECT ALTERNATIVE.

*Don't let tight quarters, and stale heads ruin your time on the water. Vent the stale air quietly and efficiently with the Head Vent System exclusively from Delta-T Systems. You can thank us later.*

- ✓ Replace those noisy and ineffective in-line fans of the past
- ✓ Vent up to 4 heads quietly and automatically with one remotely located unit
- ✓ Simple to install and plumb using either 3" or 4" piping
- ✓ Motion sensors turn the unit on and off according to owner's personal preferences
- ✓ Multiple heads can vent stale air to one location

## How it works.

[deltatsystems.com/solutions/head-vent](https://deltatsystems.com/solutions/head-vent)

- 1 Remotely placed plenum box can handle up to four heads
- 2 Motion sensors detect occupancy and initiates the flow of air
- 3 Heads are plumbed together, and stale air vented to one convenient location

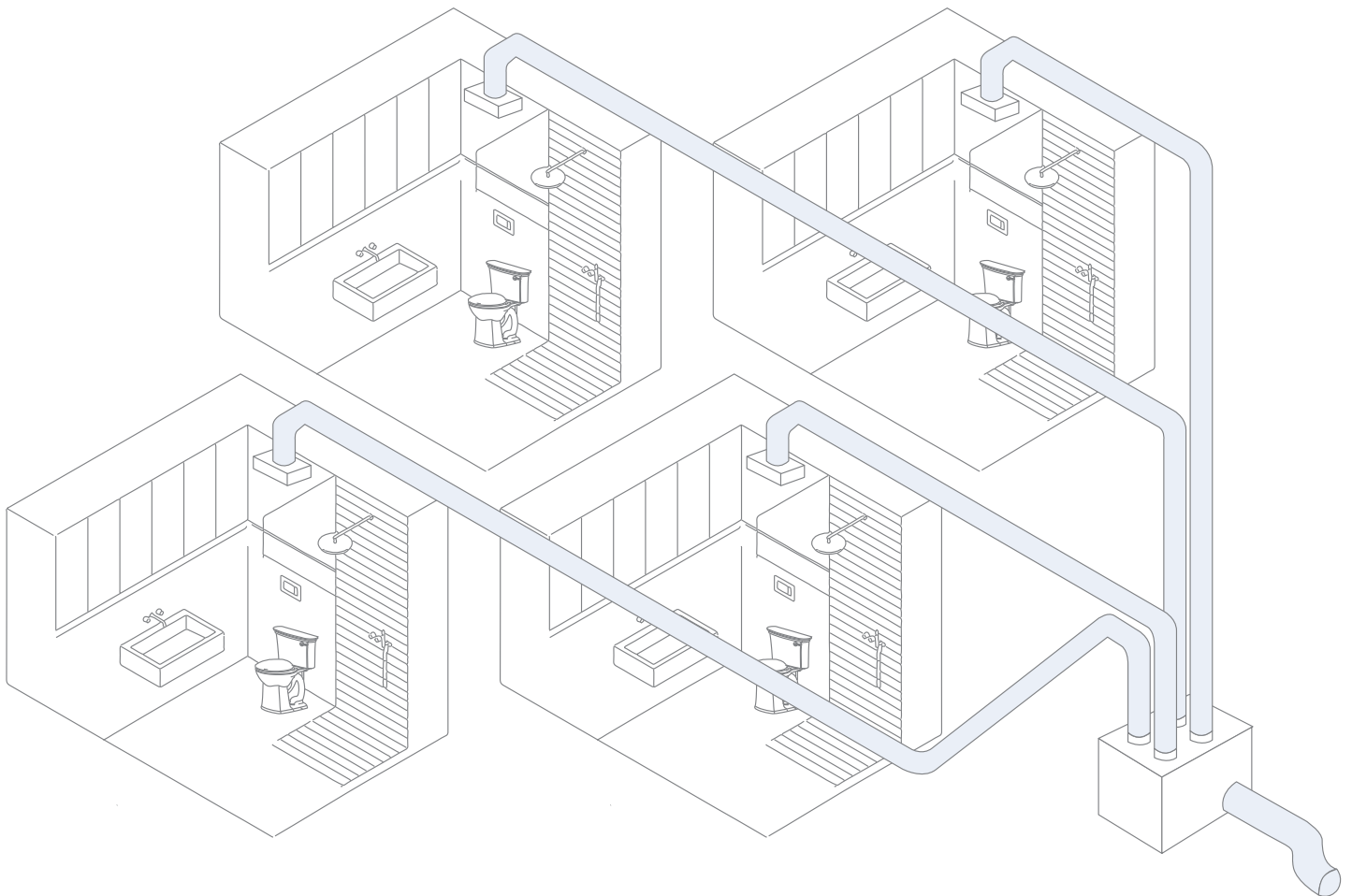



## Fans & Blowers

<https://deltatsystems.com/product/category/fans-blowers/>

---



## Control Systems

<https://deltatsystems.com/product/category/control-systems/>

---



## Moisture Eliminators

<https://deltatsystems.com/product/category/moisture-eliminators/>

---



## Fire Dampers

<https://deltatsystems.com/product/category/dampers/>

---



## Off-Load Release Hooks

<https://deltatsystems.com/solutions/off-load-release-hook/#product-categories>

---



## Head Vents

<https://deltatsystems.com/solutions/head-vent/#product-categories>











116 Plantation Oak Drive  
Thomasville, Georgia 31792

Phone: 229.228.7653  
Fax: 229.228.1270

[centekindustries.com](http://centekindustries.com)